

THIS DRAWING IS THE SOLE PROPERTY OF FURNACE ENGINEERING PTY.LTD. AND IS RETURNABLE ON REQUEST. IT IS TO BE TREATED AS CONFIDENTIAL, AND NOT TO BE COPIED OR COMMUNICATED TO ANY OTHER PERSON WITHOUT THE WRITTEN CONSENT OF FURNACE ENGINEERING PTY.LTD. IT MAY ONLY BE USED FOR MANUFACTURE WHEN ACCOMPANIED BY A WRITTEN ORDER.

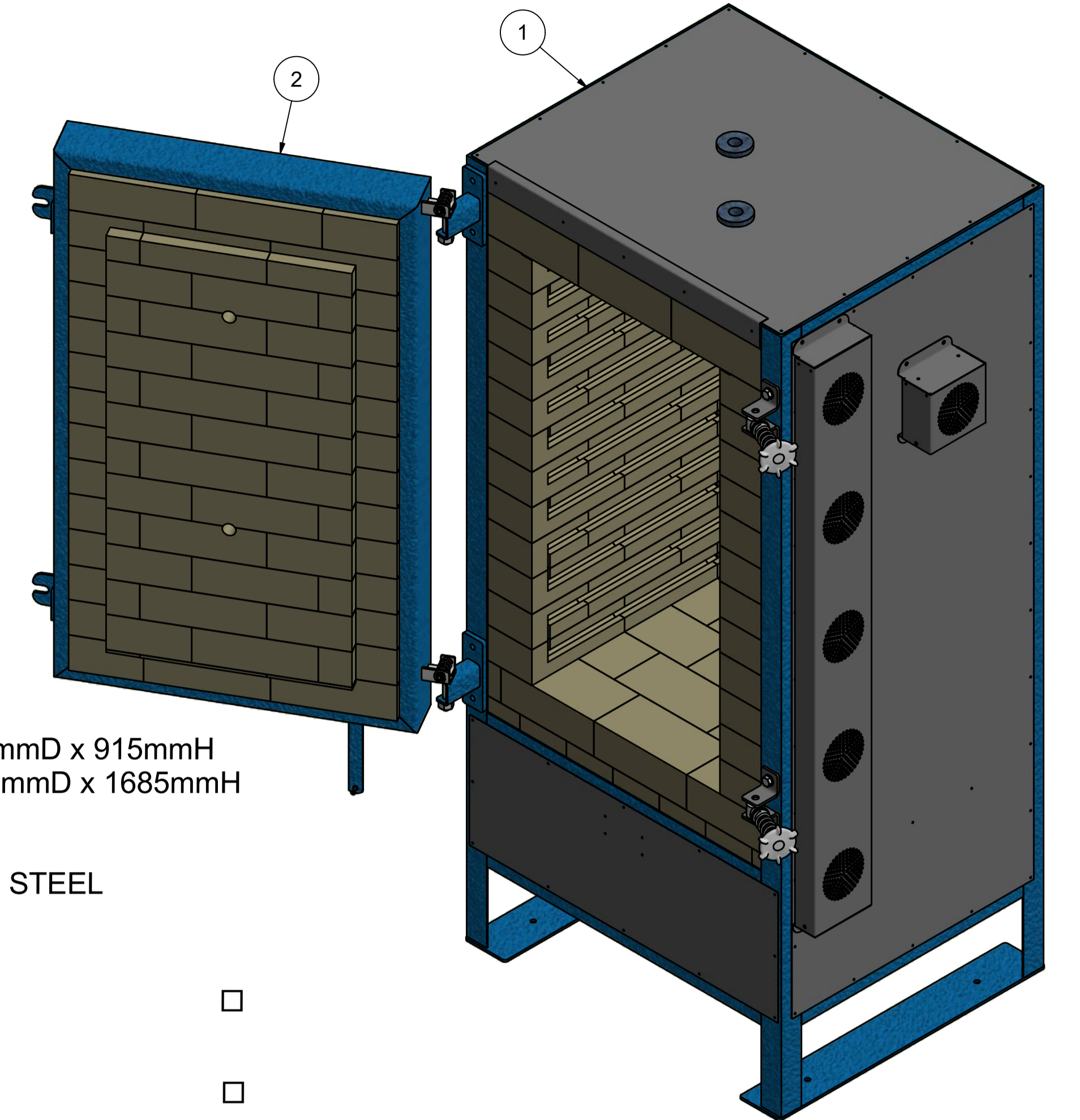

**NOTES:**  
 MODEL: K9 FL  
 INTERNAL DIMS: 460mmW x 466mmD x 915mmH  
 EXTERNAL DIMS: 864mmW x 813mmD x 1685mmH  
 REFRACTORY: LBK 23 BRICKS  
 FRAME: MILD STEEL  
 OUTER CASING: 304 STAINLESS STEEL  
 TEMPERATURE: MAX 1280°C  
 ELECTRICAL POWER

- 3 PHASE, 415V, 20amps, 14.4kW
- KILN PROGRAM**
- 1 - PROGRAMMER FITTING
- 2 - SR 92
- 3 - STAFFORD
- ADDITIONAL OPTIONS**
- 1 - ROOF VENT SYSTEM
- 2 - FLOOR VENT SYSTEM
- FOR ADDITIONAL OPTIONS - REFER TO SEPERATE DRAWINGS

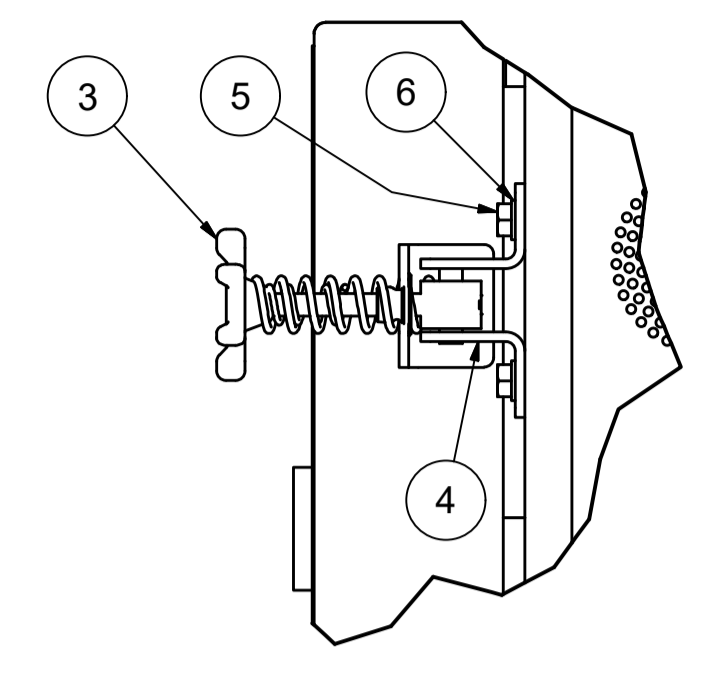
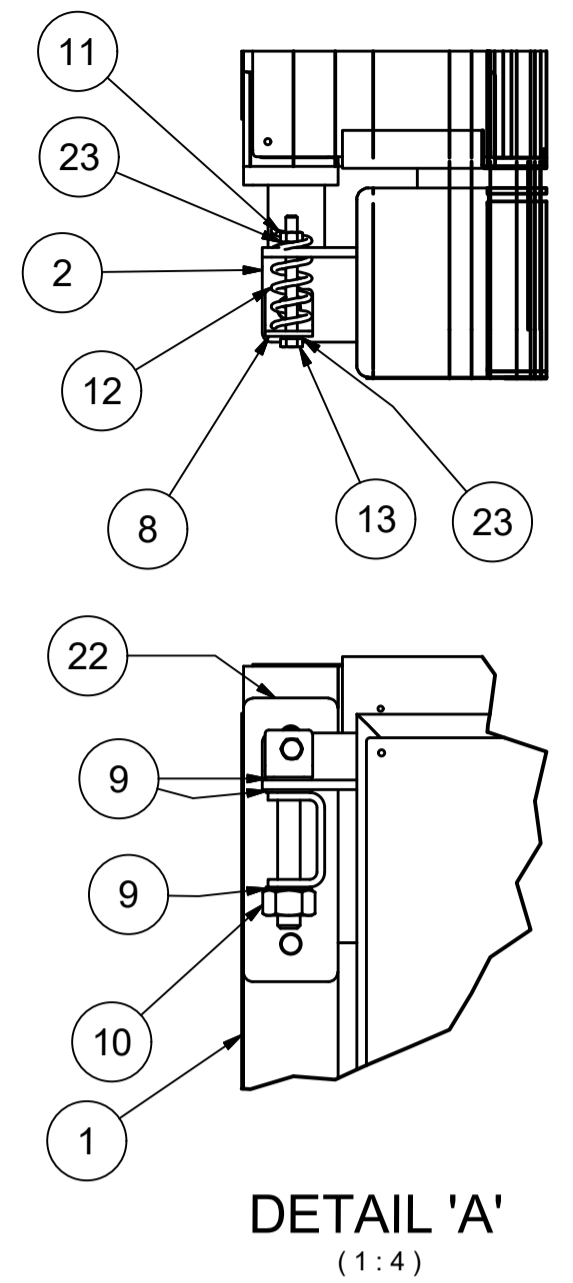
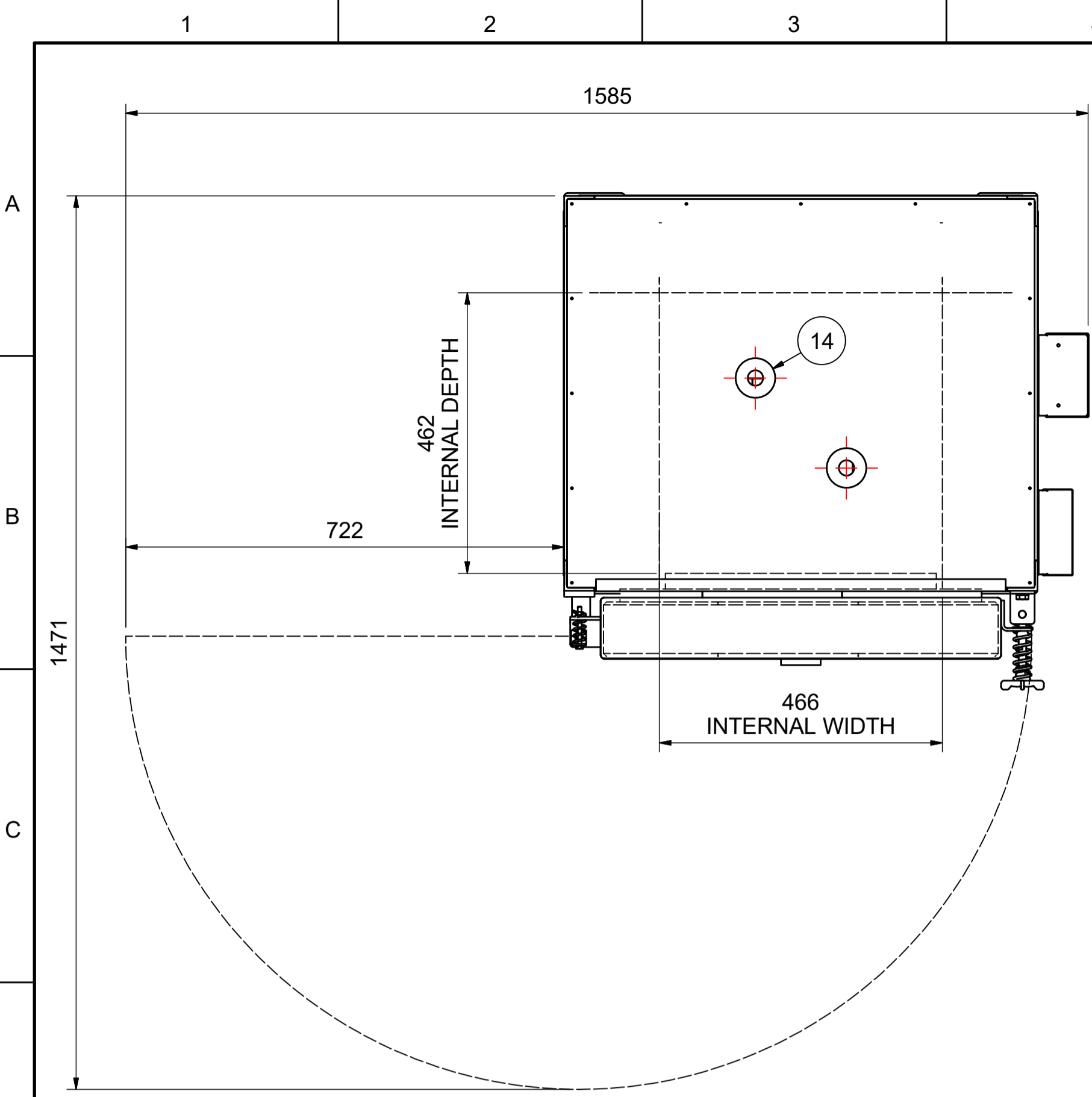
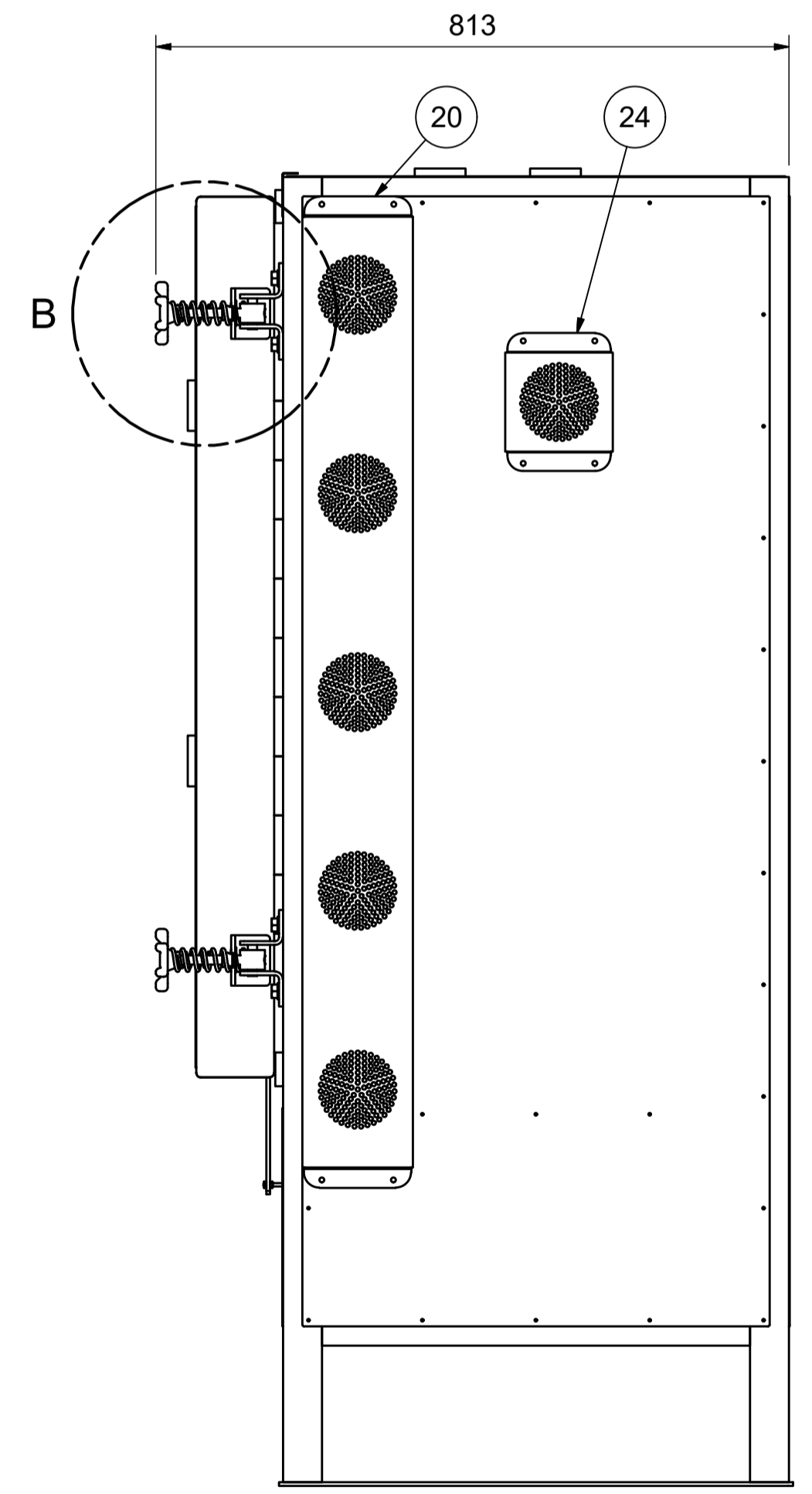
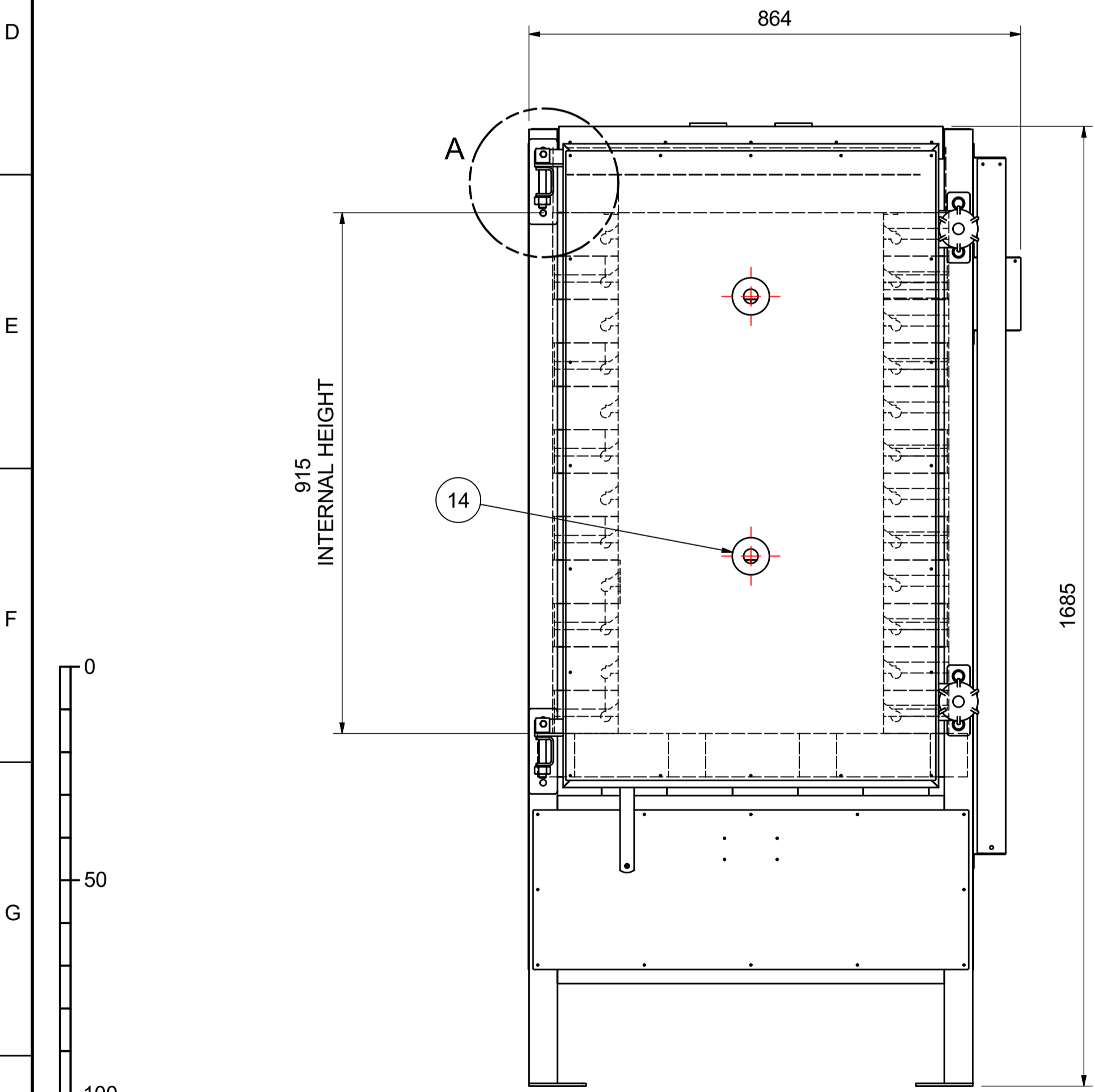

Parts List				
ITEM	QTY	DESCRIPTION	MATERIAL	PART No. DRAWING No.
1	1	KILN		K9 FL/002
2	1	DOOR		K9 FL/005
3	1	SCREW HANDLE ASSEMBLY		TET-K 0032 TET-K 0032
4	4	Front Load Handle Boss Mount Angle	304 SS	TET-K 0019 TET-K 0019
5	4	M10 x 20 Hex Hd Bolt Gr 4.6 Z/P	M.S	
6	4	M10 FLAT WASHER	M.S	
8	2	SMALL DOOR HINGE BOLT ASSEMBLY		TET-K 0027 TET-K 0027
9	6	BRASS FLAT WASHER 1/2" ID, 1" OD, 16 GAUGE	Brass	TET-K-0033 TET-K 0033
10	2	M16 Hex Nut Gr 5 Z/P	M.S	
11	2	M6 Hex Nut Gr 5 Z/P	M.S	
12	2	Small Spring	M.S	TET-K 0023 TET-K 0023
13	2	M6 x 65 Hex Hd Bolt Gr 4.6 Z/P	M.S	
14	4	PLUG HOLDER LONG		TET-K 0007 TET-K 0007
20	1	ELEMENT COVER		K9 FL/008
22	2	HINGED DOOR BRACKET		K9 FL/006
23	4	M6 Flat Washer	M.S	
24	1	THERMOCOUPLE COVER		K9 FL/008

NO	DESCRIPTION	REV BY	DATE	APPR BY
A	ORIGINAL RELEASE - NOT FOR MANUFACTURE	C.H.	2 MAR 20	-
B	RELEASED FOR MANUFACTURE	C.H.	2 MAR 20	T.N.
C	ADDED DOOR ARCH	C.H.	14 SEPT 20	T.N.

**WELD NOTES**

- CARBON STEEL STRUCTURAL WELDING TO AS 1554.1 G.P. WITH 100% VISUAL EXAMINATION, 5% VISUAL INSPECTION U.N.O.
- STAINLESS STEEL STRUCTURAL WELDING TO AS 1554.6 CATEGORY 2, CLASS C, SURFACE FINISH III WITH 100% VISUAL SCANNING, 5% VISUAL EXAMINATION U.N.O.
- ALL WELDS TO BE CONTINUOUS 0.7 x MIN. PLATE THICKNESS U.N.O.
- WELD DETAILS COVERED BY NOTES 1.2 & 3 ARE NOT SHOWN ON THE DRAWING
- CARBON STEEL WELDING CONSUMABLES TO AS 1554.1 SECTION 2.3
- STAINLESS STEEL WELDING CONSUMABLES TO AS 1554.6 SECTION 2.3
- ELECTRODE SELECTION AS PER AS 1554.6 TABLE 4.5.1 U.N.O.

**GENERAL NOTES**

- ALL ROLLED STEEL SECTIONS TO BE IN ACCORDANCE WITH AS3679.1-300 AND CURRENT BHP STRUCTURAL SHAPES
- ALL RHS & CHS TO BE GRADE 350 TO AS1163
- ALL BOLTS AND NUTS TO BE IN ACCORDANCE WITH AS1111,AS1112, AS1110,AS1252 UNLESS OTHERWISE NOTED.
- DO NOT SCALE

SURFACE FINISH	TOLERANCES:	
	AS 1100	MAX. CLA. EQUIV
NO. MIC	±0.3	
25um	±1	
1.6um	±0.5	
6.3um		
1.6um		

**RELEASED FOR MANUFACTURE**

 THIRD ANG. PROJ. AUST STD AS1100	 TETLOW KILNS & FURNACES A.B.N. 26 166 832 3000 54	<b>A1</b>
	K9 FL KILN GENERAL ARRANGEMENT	
DESIGNED: C.HILLIER DRAWN: C.HILLIER DATE: 23/03/2020 CHECKED: D.BOISSEZON APPROVED: T.NASH SCALE: 1:7.5	CLIENT:	DRG. NO. K9 FL/001
INVENTOR:	SHT. NO. 1 of 1	REV. C